

Landscape Services  
RFP FY24-SCPW-03  
Addendum #1  
Issued May 2, 2024

1. Do you happen to have maps or addresses for each of the locations in the RFP?

Property Addresses:

1. Sandoval County La Plazuela Complex – 1500 Idalia Road, Bernalillo, NM 87004
  - a. Judicial Complex – Building A
  - b. Administration – Building D
  - c. Health Commons – Building B
  - d. La Plazuela Transit – Building C
2. El Zocalo – 264/284 S. Camino Del Pueblo, Bernalillo, NM 87004
3. Sandoval County Courthouse – 711 S. Camino Del Pueblo, Bernalillo, NM 87004
4. Magistrate Court – 1000 Montoya Road, Bernalillo, NM 87004
5. Bernalillo Senior Center – 840 Rotary Park, Bernalillo, NM 87004
6. Public Safety Building/EOC – 7225 Orestead Road, Bernalillo, NM 87004

Ten maps have been attached to this document. The list below indicates which map is associated with which building/location.

1. Sandoval County La Plazuela Complex – See map 1
  - a. Judicial Complex – See map 2
  - b. Administration – See maps 3 & 4
  - c. Health Commons – See maps 3 & 4
  - d. La Plazuela Transit – See maps 4 & 5
2. El Zocalo – See maps 6, 7, & 8
3. Sandoval County Courthouse – See map 9
4. Magistrate Court – See map 10
5. Bernalillo Senior Center – We do not have a map on file for this location, but it can be picked up on Google maps.
6. Public Safety Building/EOC – See map 4

#1

### SKETCH/AREA TABLE ADDENDUM

SUBJECT	Property Address	Grass Field	
	City	State	Zip
	Owner		
	Client		
	Appraiser Name		

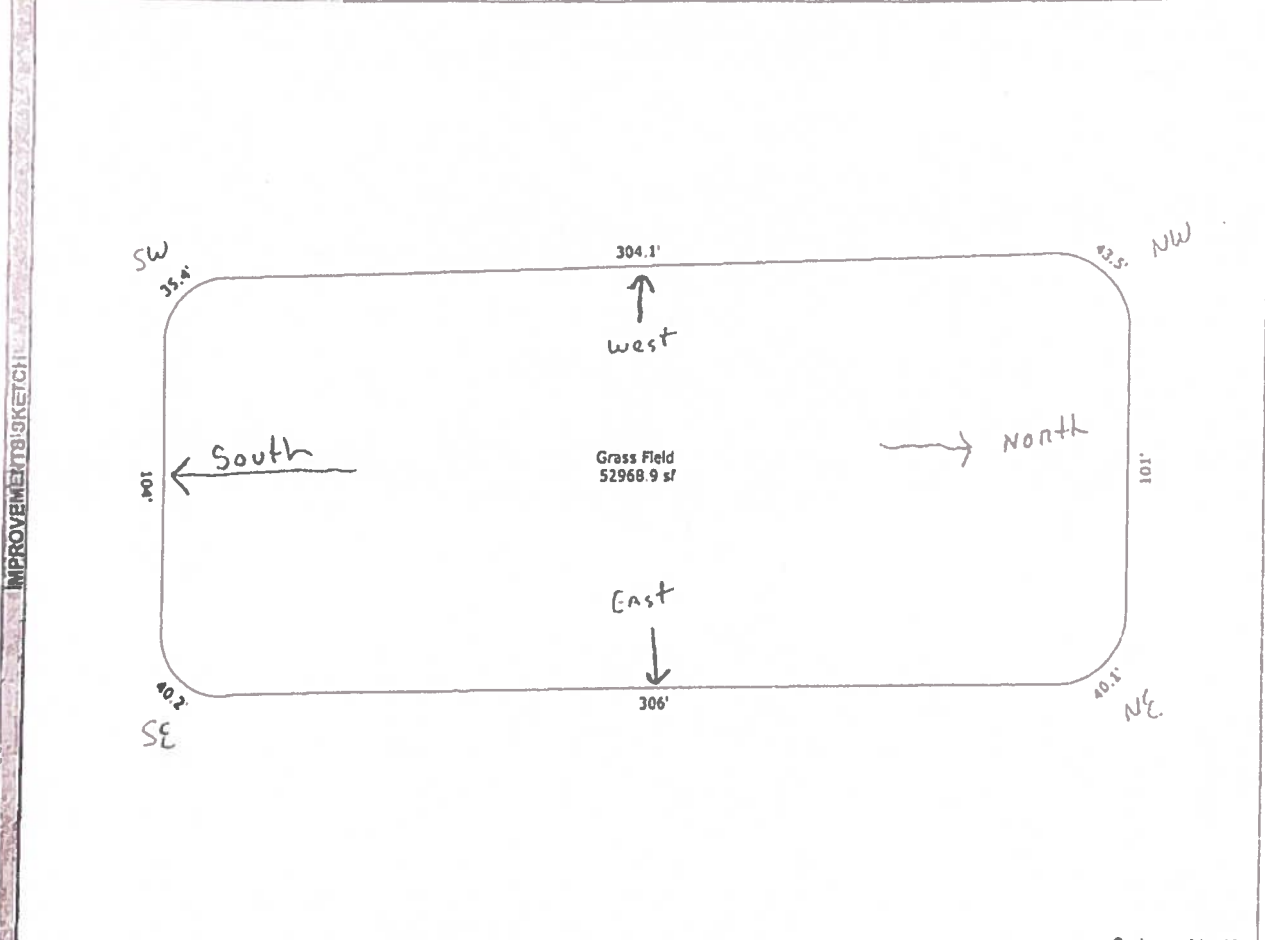

AREA CALCULATIONS SUMMARY					
Code	Description	Factor	Net Size	Perimeter	Net Totals
GLA1	Grass Field	1.00	52968.89	974.4	52968.89
<b>Net LIVABLE Area</b>		<b>(rounded w/ factors)</b>			<b>52869</b>

Comment Table 1	
Comment Table 2	Comment Table 3

AREA CALCULATIONS

#2

### SKETCH/AREA TABLE ADDENDUM

Property Address: Judicial Complex Building A Landscape  
 City: \_\_\_\_\_ State: \_\_\_\_\_ Zip: \_\_\_\_\_  
 Owner: \_\_\_\_\_  
 Client: \_\_\_\_\_  
 Appraiser Name: \_\_\_\_\_

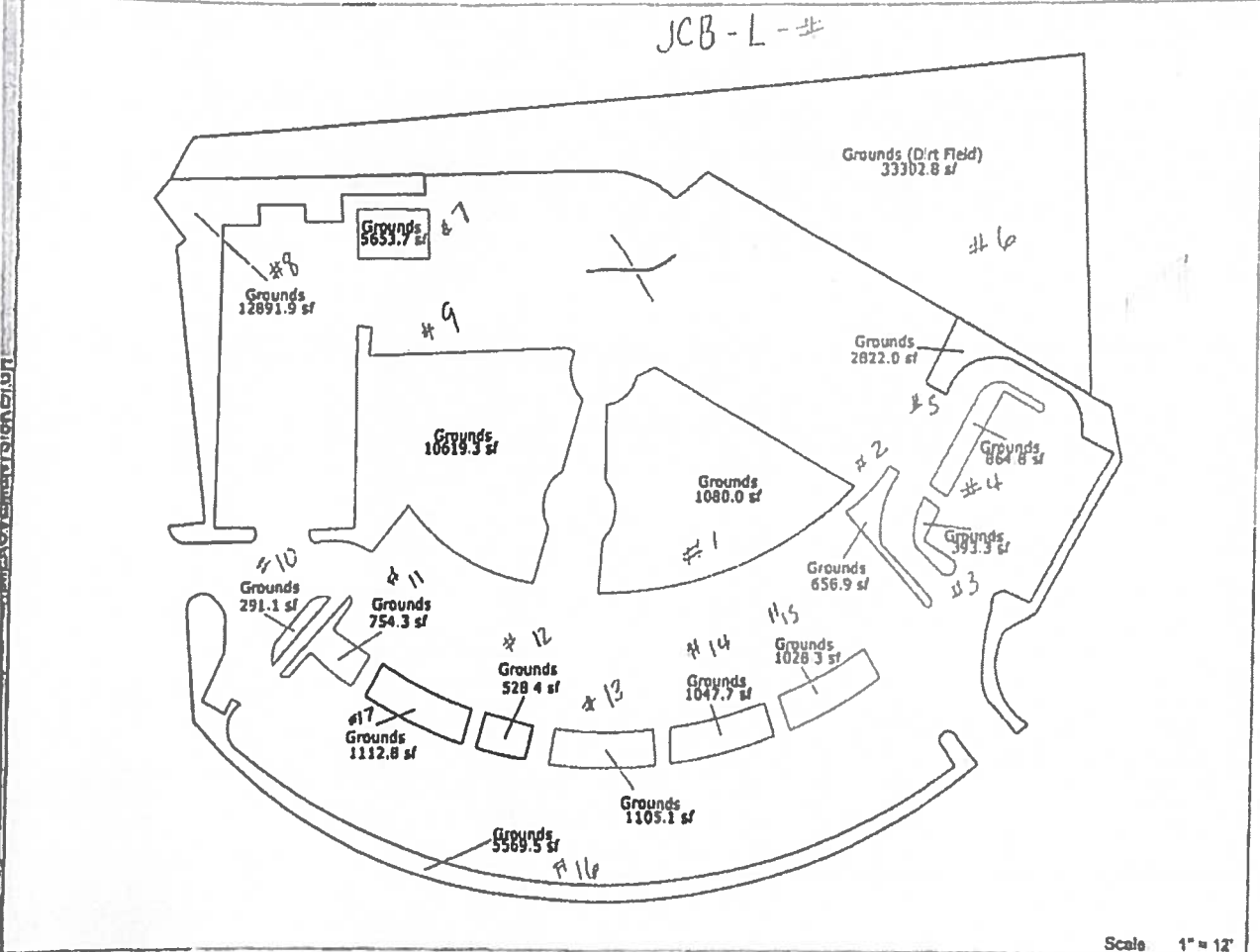

Scale 1" = 12'

AREA CALCULATIONS SUMMARY					Comment Table 1	
Code	Description	Factor	Net Size	Perimeter	Net Totals	
GLA1	Grounds	1.00	10619.26	431.2		
	Grounds	1.00	1080.00	134.0		
	Grounds	1.00	5653.70	764.1		
	Grounds	1.00	12891.88	567.9		
	Grounds	1.00	291.09	100.6		
	Grounds	1.00	754.26	174.4		
	Grounds	1.00	1112.81	155.1		
	Grounds	1.00	528.43	92.8		
	Grounds	1.00	1105.07	183.7		
	Grounds	1.00	1047.66	150.9		
	Grounds	1.00	1028.26	148.6		
	Grounds	1.00	5569.54	1164.4		
	Grounds	1.00	656.94	198.4		
	Grounds	1.00	393.30	112.8		
	Grounds	1.00	864.82	201.8		
	Grounds	1.00	2822.00	677.2		
	Grounds	1.00	33302.79	1268.3	79721.79	
<b>Net LIVABLE Area (rounded w/ factors)</b>					<b>79722</b>	Comment Table 2
						Comment Table 3

#3

### SKETCH/AREA TABLE ADDENDUM

**SUBJECT:** Property Address ADM. So. Landscape  
 City \_\_\_\_\_ State \_\_\_\_\_ Zip \_\_\_\_\_  
 Owner \_\_\_\_\_  
 Client \_\_\_\_\_  
 Appraiser Name \_\_\_\_\_

ADM-50-L-#

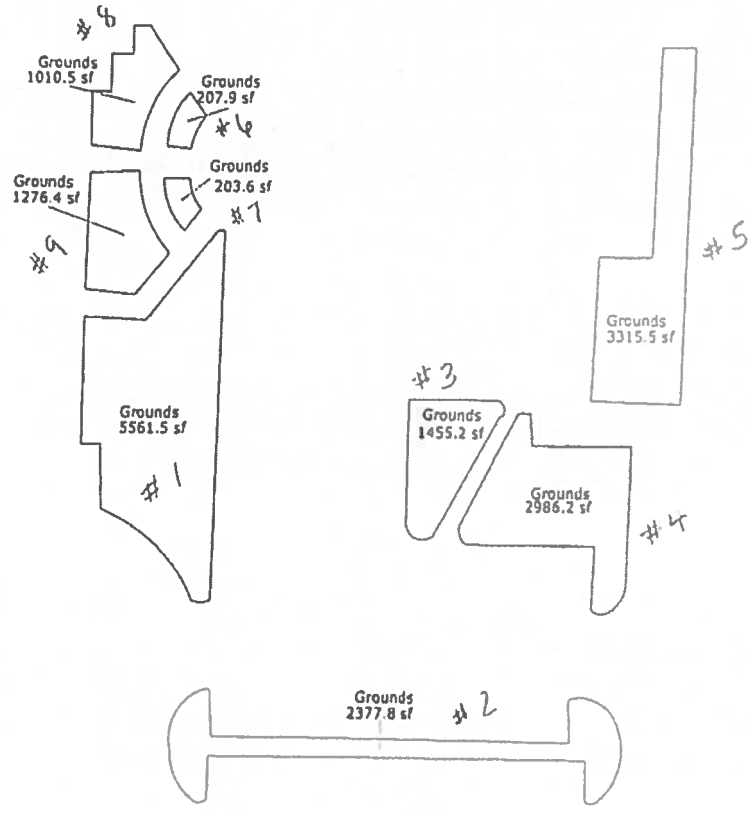

Scale 1" = 12'

#### AREA CALCULATIONS SUMMARY

Code	Description	Factor	Net Size	Perimeter	Net Totals
GLA1	First Floor	1.00	2986.18	274.4	
	First Floor	1.00	5561.55	371.1	
	First Floor	1.00	203.59	59.2	
	First Floor	1.00	207.86	59.4	
	First Floor	1.00	1276.43	147.5	
	First Floor	1.00	1010.53	149.2	
	First Floor	1.00	2377.80	502.9	
	First Floor	1.00	Open		
	First Floor	1.00	Open		
Net LIVABLE Area			(rounded w/ factors)		Open

Comment Table 1	
18394.6 Sq. Ft.	
Comment Table 2	Comment Table 3

AREA CALCULATIONS

### SKETCH/AREA TABLE ADDENDUM

**SUBJECT**

Property Address ADM. No. Landscape  
 City State Zip  
 Owner  
 Client  
 Appraiser Name

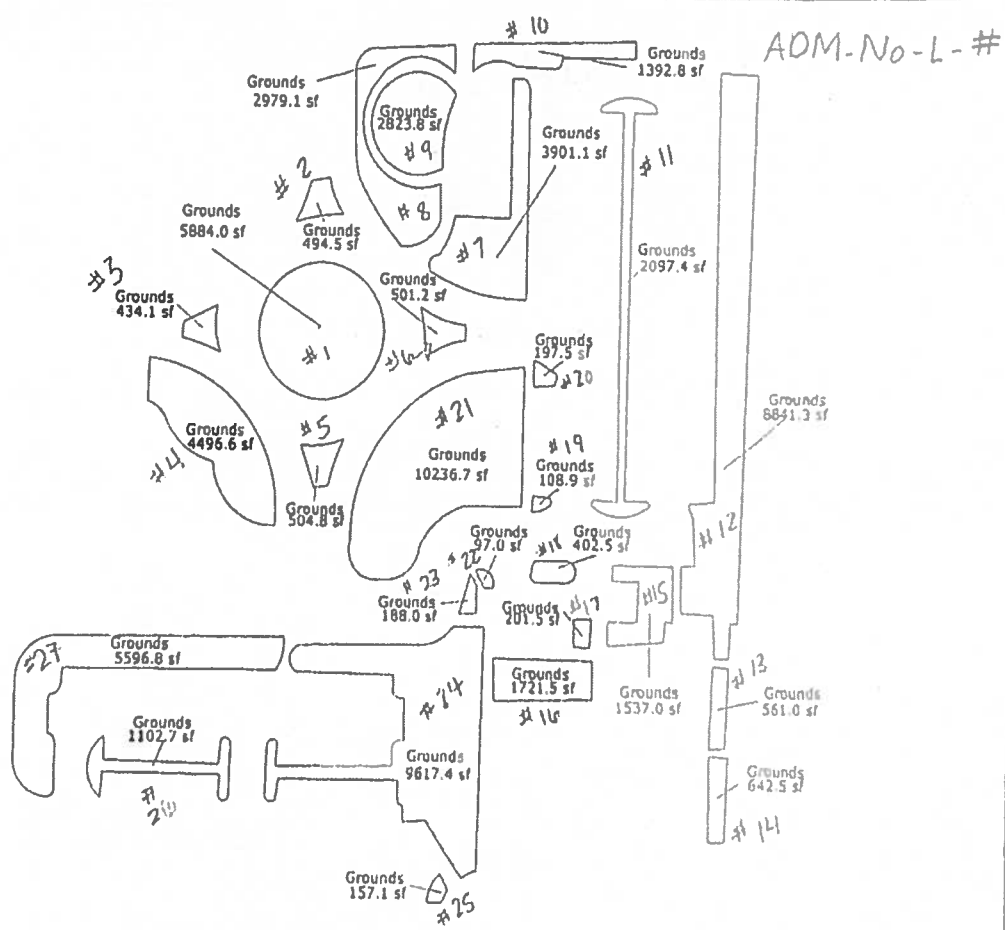

**AREA CALCULATIONS SUMMARY**

Code	Description	Factor	Net Size	Perimeter	Net Totals
GLA1	First Floor	1.00	10236.66	429.0	
	First Floor	1.00	5883.96	272.0	
	First Floor	1.00	501.18	105.1	
	First Floor	1.00	504.84	101.2	
	First Floor	1.00	434.14	93.6	
	First Floor	1.00	3901.06	386.9	
	First Floor	1.00	2823.76	197.3	
	First Floor	1.00	2979.14	437.8	
	First Floor	1.00	494.47	99.9	
	First Floor	1.00	2097.38	654.7	
	First Floor	1.00	402.54	80.5	
	First Floor	1.00	1537.00	222.3	
	First Floor	1.00	201.50	98.1	
	First Floor	1.00	1721.50	186.1	
	First Floor	1.00	108.93	41.6	
	First Floor	1.00	197.80	57.3	
	First Floor	1.00	5596.82	543.3	
	First Floor	1.00	9617.40	780.0	
	First Floor	1.00	561.00	124.2	
	First Floor	1.00	642.50	131.1	
	First Floor	1.00	1102.65	315.9	
	First Floor	1.00	8841.35	827.3	
<b>Net LIVABLE Area</b>			<b>(rounded w/ factors)</b>		<b>66719</b>

Scale: 1" = 12'

Comment Table 1

66747.3 Sq. Ft.

Comment Table 2    Comment Table 3

AREA CALCULATIONS

#5

### SKETCH/AREA TABLE ADDENDUM

Property Address		ADM. No. Landscape	
City	State	Zip	
Owner	Client		
Appraiser Name			

Health Commers  
Bldg

Admin.  
Bldg

AREA CALCULATIONS SUMMARY				
Code	Description	Factor	Net Bldg	Perimeter
00.01	First Floor	1.00	10236.68	429.0
	First Floor	1.00	8809.90	372.0
	First Floor	1.00	801.10	105.1
	First Floor	1.00	804.80	101.2
	First Floor	2.00	434.14	93.6
	First Floor	2.00	3901.00	386.9
	First Floor	1.00	3023.74	197.3
	First Floor	1.00	2979.14	437.0
	First Floor	1.00	494.47	98.9
	First Floor	1.00	2097.30	604.7
	First Floor	1.00	402.84	80.8
	First Floor	1.00	1537.00	222.3
	First Floor	1.00	201.80	88.1
	First Floor	1.00	1721.00	106.1
	First Floor	1.00	100.93	41.6
	First Floor	1.00	197.80	87.3
	First Floor	1.00	8896.02	543.3
	First Floor	1.00	9817.40	780.0
	First Floor	1.00	881.00	124.2
	First Floor	1.00	442.80	131.1
	First Floor	1.00	1102.48	315.9
	First Floor	1.00	8041.35	827.3
<b>Net LIVABLE Area</b>			(rounded w/ factors)	<b>86719</b>

Comment Table 1		
Comment Table 2	Comment Table 3	

#6

### SKETCH/AREA TABLE ADDENDUM

**SUBJECT**

Property Address **El Zocalo Convent Building**

City \_\_\_\_\_ State \_\_\_\_\_ Zip \_\_\_\_\_

Owner \_\_\_\_\_

Client \_\_\_\_\_

Appraiser Name \_\_\_\_\_

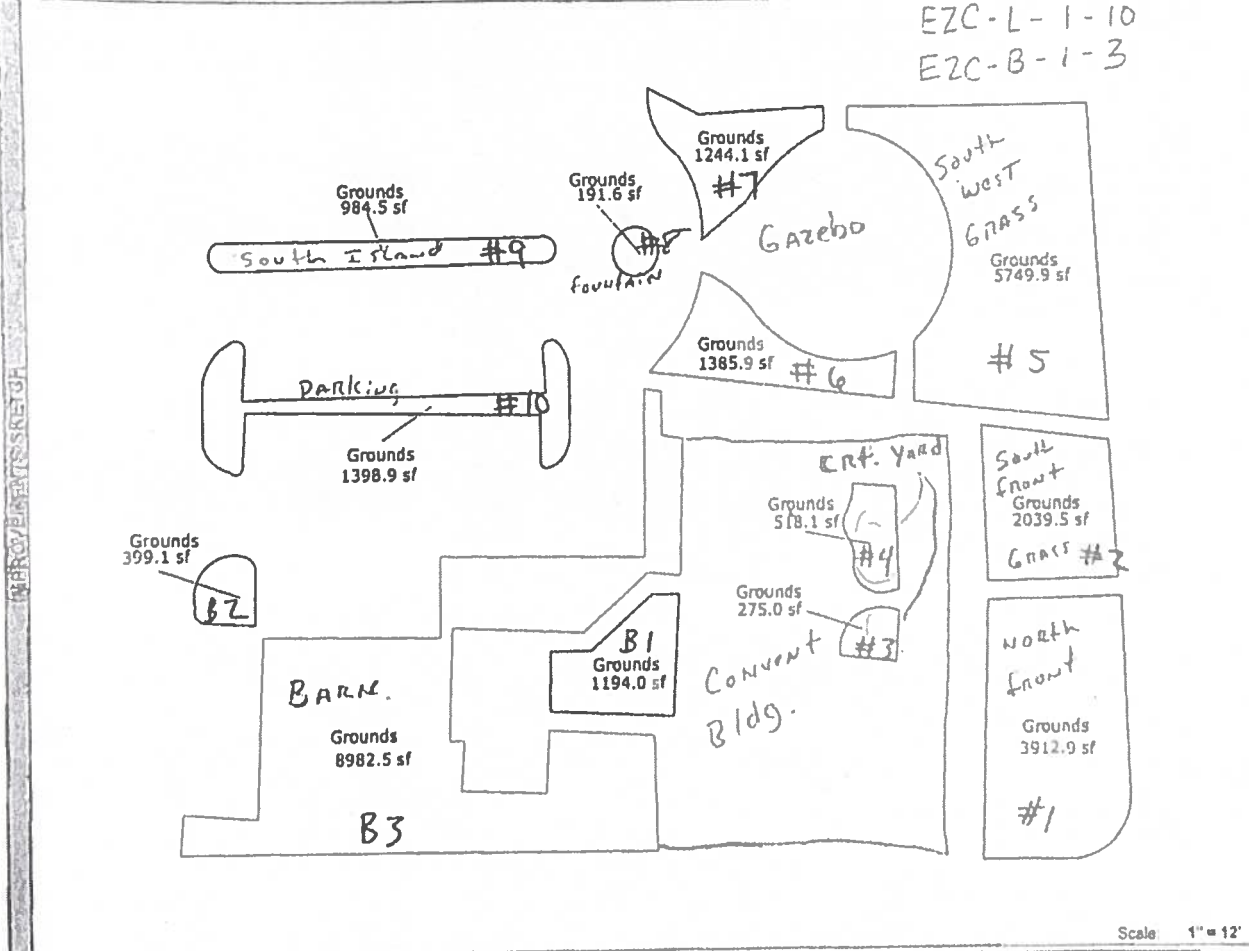

Scale 1" = 12'

AREA CALCULATIONS SUMMARY						Comment Table 1			
Code	Description	Factor	Net Size	Perimeter	Net Totals				
CLA1	Grounds	1.00	3912.94	253.6					
	Grounds	1.00	2039.50	181.4					
	Grounds	1.00	5749.90	365.7					
	Grounds	1.00	1244.12	177.2					
	Grounds	1.00	1385.85	211.8					
	Grounds	1.00	8982.50	803.7					
	Grounds	1.00	1194.00	150.8					
	Grounds	1.00	399.13	75.3					
	Grounds	1.00	1398.07	382.8					
	Grounds	1.00	984.47	244.7					
	Grounds	1.00	191.63	49.1		Total			
	Grounds	1.00	518.11	94.9			28276.05		
	Grounds	1.00	275.02	64.7				Sq ft	
				17,700.4					
			10,575.6						
			Total 28,276.05						
Net LIVABLE Area			(rounded w/ factors)		28276				

AREA CALCULATIONS

#7

# SKETCH/AREA TABLE ADDENDUM

SUBJECT	Property Address	El Zocalo Convent Building		
	City	State	Zip	
	Owner			
	Client			
	Appraiser Name			

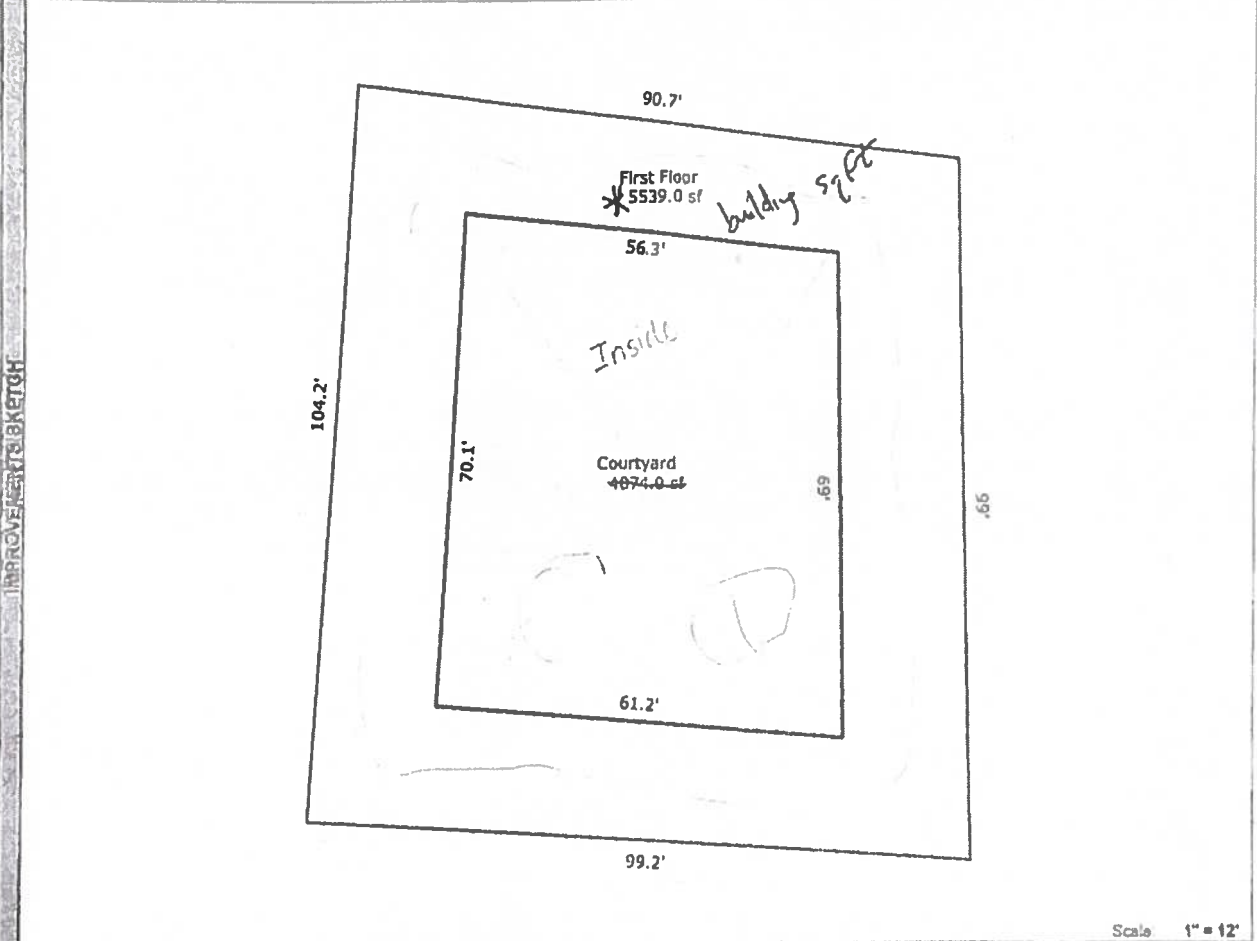

Scale 1" = 12'

AREA CALCULATIONS

AREA CALCULATIONS SUMMARY					
Code	Description	Factor	Net Size	Perimeter	Net Totals
GLA1	First Floor	1.00	9613.00	393.1	9613.00
CTYD	Courtyard	1.00	9613.00	393.1	9613.00
Net LIVABLE Area (rounded w/ factors)					9613

Comment Table 1	
Comment Table 2	Comment Table 3





### SKETCH/AREA TABLE ADDENDUM

**SUBJECT**

Property Address Old Courthouse Landscape

City \_\_\_\_\_ State \_\_\_\_\_ Zip \_\_\_\_\_

Owner \_\_\_\_\_

Client \_\_\_\_\_

Appraiser Name \_\_\_\_\_

OCH-L-#1

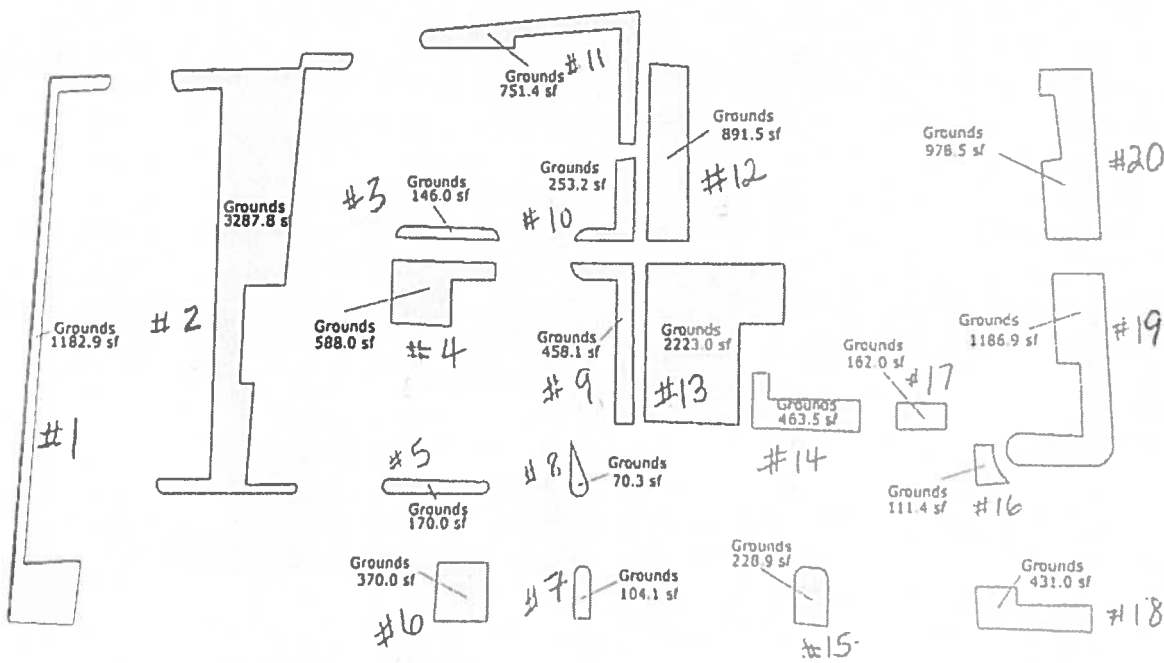

Scale: 1" = 12'

#### AREA CALCULATIONS SUMMARY

Code	Description	Factor	Net Size	Perimeter	Net Totals
GLA1	Grounds	1.00	1182.90	459.0	
	Grounds	1.00	3287.79	507.3	
	Grounds	1.00	370.00	77.0	
	Grounds	1.00	170.01	82.9	
	Grounds	1.00	588.00	120.0	
	Grounds	1.00	145.96	80.7	
	Grounds	1.00	104.14	45.4	
	Grounds	1.00	228.92	60.1	
	Grounds	1.00	431.00	110.0	
	Grounds	1.00	70.32	43.2	
	Grounds	1.00	111.43	48.1	
	Grounds	1.00	1186.90	215.4	
	Grounds	1.00	978.90	166.5	
	Grounds	1.00	463.90	117.0	
	Grounds	1.00	2223.00	211.0	
	Grounds	1.00	891.50	152.0	
	Grounds	1.00	751.37	254.7	
	Grounds	1.00	253.21	98.8	
	Grounds	1.00	458.06	156.4	
	Grounds	1.00	162.00	54.0	14058.50
Net LIVABLE Area (rounded w/ factors)					14059

Comment Table 1

Comment Table 2

Comment Table 3

AREA CALCULATIONS

#10

# MAGISTRATE COURT SKETCH/AREA TABLE ADDENDUM

**PROPERTY ADDRESS** MAGISTRATE COURT  
**CITY** Orlando Building Landscape  
**OWNER** \_\_\_\_\_ **STATE** \_\_\_\_\_ **ZIP** \_\_\_\_\_  
**CLIENT** \_\_\_\_\_  
**APPRAISER NAME** \_\_\_\_\_

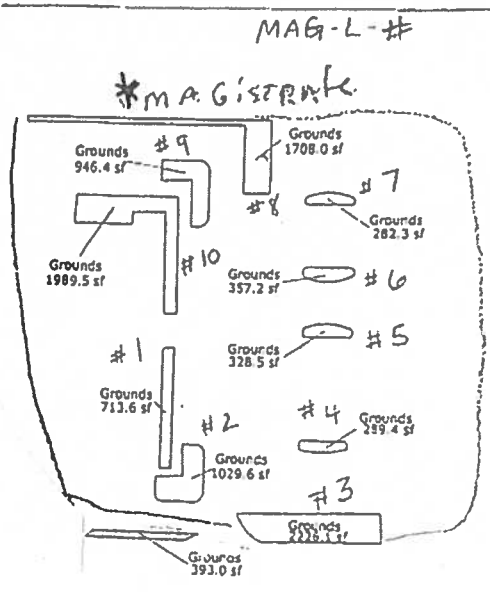

## AREA CALCULATIONS SUMMARY

Scale: 1" = 12'

Code	Description	Factor	Net Size	Perimeter	Net Totals
GLA1	Grounds	1.00	1989.50	348.1	
	Grounds	1.00	946.42	164.7	
	Grounds	1.00	1708.00	474.8	
	Grounds	1.00	282.32	84.3	
	Grounds	1.00	357.25	88.6	
	Grounds	1.00	328.54	85.1	
	Grounds	1.00	289.37	83.8	
	Grounds	1.00	2226.12	251.4	
	Grounds	1.00	713.60	194.5	
	Grounds	1.00	1029.58	148.3	
	Grounds	1.00	393.00	173.0	
	Grounds	1.00	2803.34	478.0	
	Grounds	1.00	1254.00	188.0	
	Grounds	1.00	481.00	110.0	
	Grounds	1.00	198.00	58.0	
	Grounds	1.00	528.50	309.0	
	Grounds	1.00	652.50	133.0	
	Grounds	1.00	540.00	233.2	
	Grounds	1.00	1079.49	240.1	
	Grounds	1.00	304.67	84.3	
	Grounds	1.00	306.65	84.3	
	Grounds	1.00	377.54	86.9	
<b>Net LIVABLE Area</b>			<b>(rounded w/ factors)</b>		<b>22900</b>

Comment Table 1

---

Comment Table 2 | Comment Table 3